

8 - 25 Investigation of the Baking Deformation Control Scheme for a Thin-wall Arc Chamber

Chai Zhen^{1,2}, Meng Jun^{1,2}, Luo Cheng^{1,2}, Yang Weishun^{1,2}, Xie Wenjun¹, Jiao Jiqiang¹, Wei Ningfei¹ and Ma Xiangli¹

(¹Institute of Modern Physics, Chinese Academy of Sciences, Lanzhou 730000, China;

²University of Chinese Academy of Sciences, Beijing 100049, China)

The pulsed dipole magnets with a field ramping rate of up to 12 T/s will be used in the Booster Ring (BRing) of High Intensity Heavy Ion Accelerator Facility (HIAF)^[1]. To reduce the eddy current effect as well as the magnetic hysteresis that results from the rapid ramping of magnetic field, a 0.3 mm stainless steel ceramic-lined thin-wall arc vacuum chamber has been proposed^[2]. However, the longitudinal stiffness of the thin-wall vacuum chamber is poor compared to the conventional thick-wall dipole iron vacuum. During the in-line baking process, large longitudinal, radial and angular variations would occur as shown in Fig.1 (left). These deformations could seriously affect the quality and lifetime of the beam flow. Therefore, the baking deformation of the thin-wall arc chamber is a critical issue that needs to be investigated.

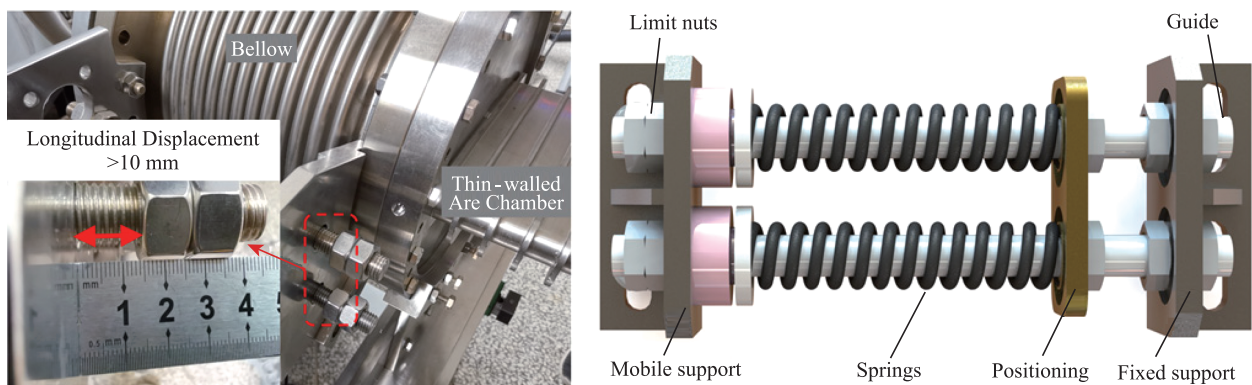

Fig. 1 (color online) The longitudinal deformation of thin-wall arc chamber (left); The diagram of spring device for deformation control (right)

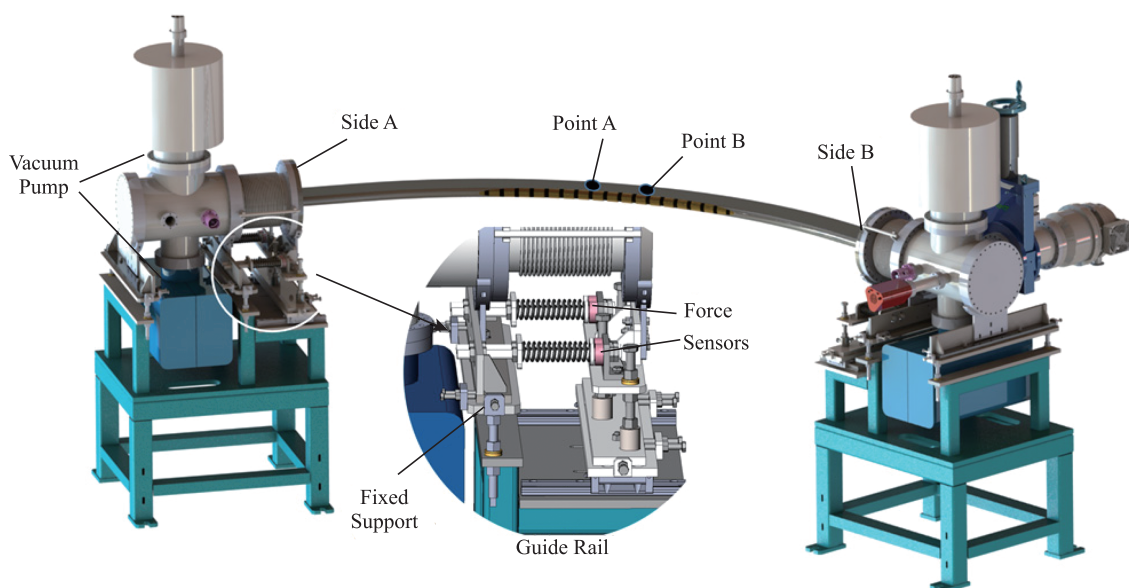

Fig. 2 (color online) Schematic diagram of the experimental device.

To solve the important problems mentioned above, a spring-centered scheme and device for baking deformation control has been proposed and tested as shown in Fig. 2 (right). And the experimental verification of the deformation

control was carried out on ceramic-lined thin-wall vacuum chambers for HIAF and SESRI 300 MeV accelerator. The results showed that the longitudinal, radial and angular variations could be controlled within 0.8 mm, 0.3 mm and 0.2° , respectively, for both prototypes under working condition.

The installation was improved on the BRing prototype segment in Tianshui due to limitation of installation space as shown in Fig. 2. Experiments have shown that when the spring is not mounted in the same plane as the vacuum chamber, additional upward arch deformation occurs due to the movement. Therefore, it is important to keep the forces in the same plane in the subsequent tests.

References

- [1] X. Q. Chen, J. C. Yang, J. W. Xia, et al., Nucl. Instrum. Meth. A, 920(2019)37.
 [2] C. C. Li, C. Luo, J. L. Liu, et al., Vacuum, 184,109898(2021)1.

8 - 26 Extremely High Vacuum Acquisition with BPM on BRing

Liu Jianlong, Lin Xiaojian, Xie Wenjun, Yang Weishun and Meng Jun

The vacuum inside HIAF-BRring beam tube should reach an extremely high vacuum level of 10^{-12} mbar. BPM is an important component for measuring beam profiles, and a total of 40 sets of BPM are distributed on BRing. BPM has a complex structure, which is one of the important issues to define whether BRing can reach extremely high vacuum.

In order to obtain better vacuum performance of BPM structure, the internal structure of BPM is continuously optimized, and the vacuum pressure of different structures of BPM is simulated. The simulation results are shown in Fig. 1, and the results show that:

(1) The denser the openings on the inner plate of BPM, the smaller the air output on the surface of the material, and the better the vacuum degree of the BPM structure.

(2) When 2 titanium sublimation pumps are configured on the BPM, the vacuum pressure of BPM with 720 holes is better than 6.7×10^{-12} mbar.

In addition, the ultimate vacuum test results of the BPM structure with a number of 720 holes processed were 6.4×10^{-12} mbar. The experimental results are shown in Fig. 2, and the experimental results agree well with the simulation results.

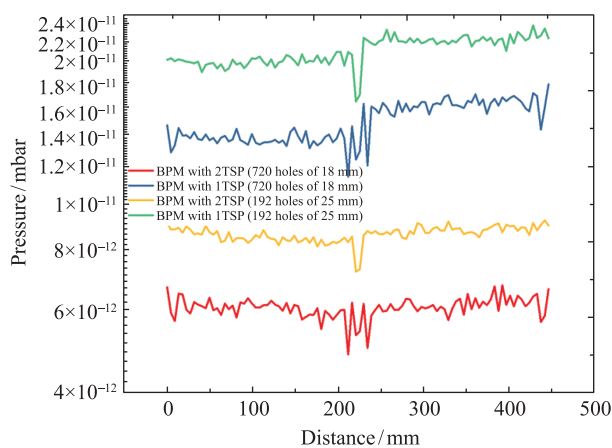

Fig. 1 (color online) Simulation results of different structures of BPM.



Fig. 2 (color online) Experimental setup with a 720-holes BPM.